

# Biobehavioral Health Building

University Park, PA

## Thesis Proposal

2012-2013 AE Senior Thesis



Rendering provided by BCJ

*Daniel Bodde*

*Structural Option*

*Advisor: Heather Sustersic*

*12/14/2012*

# Tech 3 Report

Daniel Bodde

Advisor: Heather Sustersic

---

## Table of Contents

Executive Summary.....	3
Building Introduction .....	4
Structural Overview .....	5
Foundation.....	5
Floor/Framing System.....	6
Lateral System.....	8
Design Codes.....	10
Material Properties.....	10
Design Loads .....	11
Dead.....	11
Live.....	12
Snow.....	12
Problem Statement.....	13
Proposed Solution.....	13
Breadth Topics .....	14
Façade Study.....	14
Construction Management.....	14
Tasks and Tools .....	15
Schedule.....	17
Conclusion.....	18

## Tech 3 Report

Daniel Bodde

Advisor: Heather Sustersic

---

### Executive Summary

Due to unforeseen circumstances, structural steel has been determined to be an unfeasible option for the construction of the BBH building. For this reason the new structure will be supported by using reinforced concrete. The floors will be redesigned using two-way flat slabs and/or one way slabs with interior beams. Lateral loads will be resisted by concrete moment frames in both directions. With the increased weight from using concrete, the foundations will need to be checked for strength and adjusted in size if need be.

The change to reinforced concrete will impact both the cost and schedule of the project. To alleviate this, the façade will be constructed using a precast system. A study will be done to determine how this would impact the detailing, construction, and cost of the façade. Both the concrete and façade redesign will affect the schedule's critical path. This is why a new schedule will be constructed with these changes to show the impact.

A list of tasks and tools was developed in order to create a guide of what had to be done and what tools would be needed to complete these tasks. From this a schedule was developed. The schedule shows each task with an approximate duration. This schedule will help in the time management for the completion of this senior thesis in the spring.

## Tech 3 Report

Daniel Bodde

Advisor: Heather Sustersic

### Building Introduction

Located on the campus of the Pennsylvania State University in University Park, Pennsylvania is the Biobehavioral Health Building (Figure 1). It is currently under construction and is scheduled to be finish in November 2012. When completed, it will house faculty and graduate students from the College of Health and Human Development. The overall project cost is approximately \$40,000,000 and is being funded by the Pennsylvania Department of General Services. The BBH Building is comprised of 5 stories above grade (including a penthouse) and has a full basement 100% below grade.

The BBH Building was designed to blend with that existing architecture that surrounds it. The majority of the façade was designed to mimic Henderson North's Georgian style architecture with its large amount of hand placed brick and limestone. On the northeast portion of the building the design is more modern to replicate HUB, which is a popular student hang out. Since a portion of the BBH building protruded into the HUB Lawn, which is a popular student hangout, a terrace has been provided (Figure 2). Not only does this offer a relaxing place for students to lounge but it will also be used as a stage for future concerts. A majority of the interior space is made up of offices and conference rooms that will house faculty and graduate students from the College of Health and Human Development. One of the key interior spaces is the lecture hall, which is located on the ground floor directly below the HUB lawn terrace. It is able to seat up to 200 people and has a ceiling designed to absorb any sounds or vibrations coming from the terrace above.

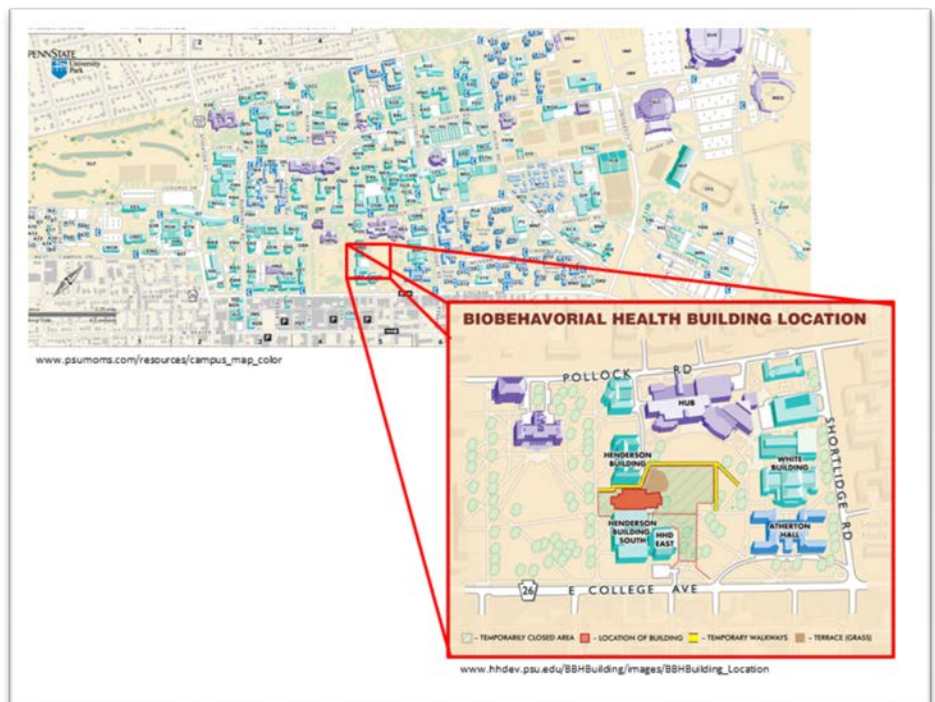

Figure 1: PSU Campus Map



Figure 2: Rendered View from HUB Lawn

# Tech 3 Report

Daniel Bodde

Advisor: Heather Sustersic

---

## Structural Overview

### Foundation

CMT Laboratories, Inc. were the geotechnical engineers hired to investigate the soil conditions on which the BBH building was to be placed. In order to better understand the soil located on the site, CMT Laboratories took six test boring samples. With the information gathered from the test borings they were able develop recommendations for the structure below grade.

It was recommended that the foundations bear on sound dolomite bedrock. According the geotechnical engineer, “the bedrock must be free of clay seams or voids near the surface to provide a stable surface to place the foundations.” If bedrock is encountered before the required bearing elevations are met then over excavation is required and needed to be back filled with lean concrete. The bearing material must have a bearing capacity of 15 psf minimum.

The BBH Building uses a shallow strip and spread footing foundation system. The strip footings are placed under the foundation walls around the perimeter of the building. These footings are at an elevation of -15’ and step down to -21’ around the lecture hall. A typical strip footing is 30” and 18” deep as shown in Figure 3. Normal weight concrete is used for all footings and must have minimum compressive 28 day strength of 4 ksi.

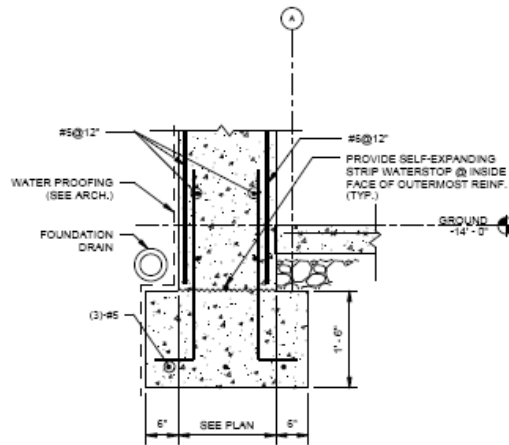

Figure 3: Typical Strip Footing

# Tech 3 Report

Daniel Bodde

Advisor: Heather Sustersic

## Floor/Framing System

The BBH Building floors are concrete slab on metal deck. The typical slab on deck consists of 3 ¼" light weight concrete on 3" 18 gage galvanized composite steel deck that is reinforced with 6"x6" W2.0xW2.0 welded wire fabric. Any deck opening that cuts through more than two deck webs needed to be reinforced. This was typically done with 4' long #4 rebar place at each corner as shown in Figure 4. This is typically done to keep the integrity of the slab and also prevents unwanted cracking in the concrete.

In order to decrease beam depth the BBH building was designed as a composite steel system. Figure 5 shows a typical section through this composite system. ¾" diameter shear studs are welded to the top flange of the beam/girder. The number of shear studs varies per beam/girder. The typical floor plan has beams spanning N-S and girder spanning E-W. See Figure 6 for a typical floor plan.

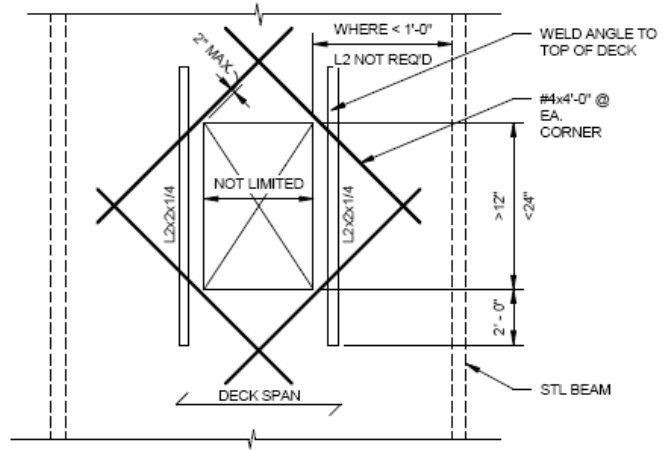

Figure 4: Openings in Slab on Steel Deck

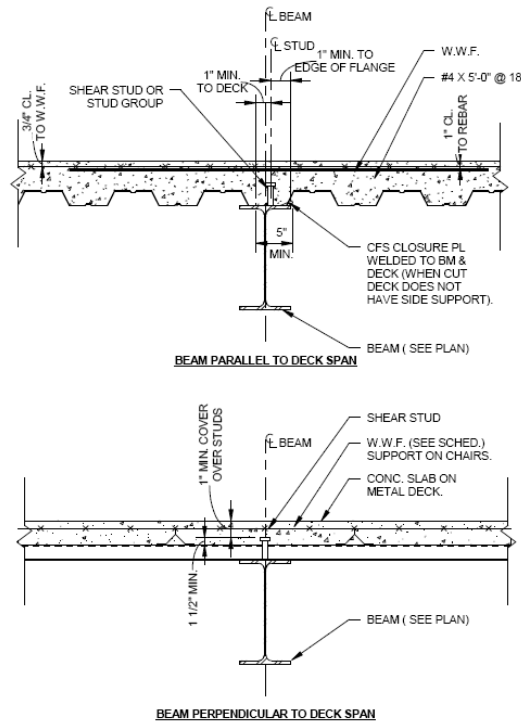

Figure 5: Typical Section Through Composite System

# Tech 3 Report

Daniel Bodde

Advisor: Heather Sustersic

The composite slab supports gravity loads and transfers that load to the beams. The beams then transfer the load to the girders, which transfer the load to the columns. Finally the load is terminated at the foundations.

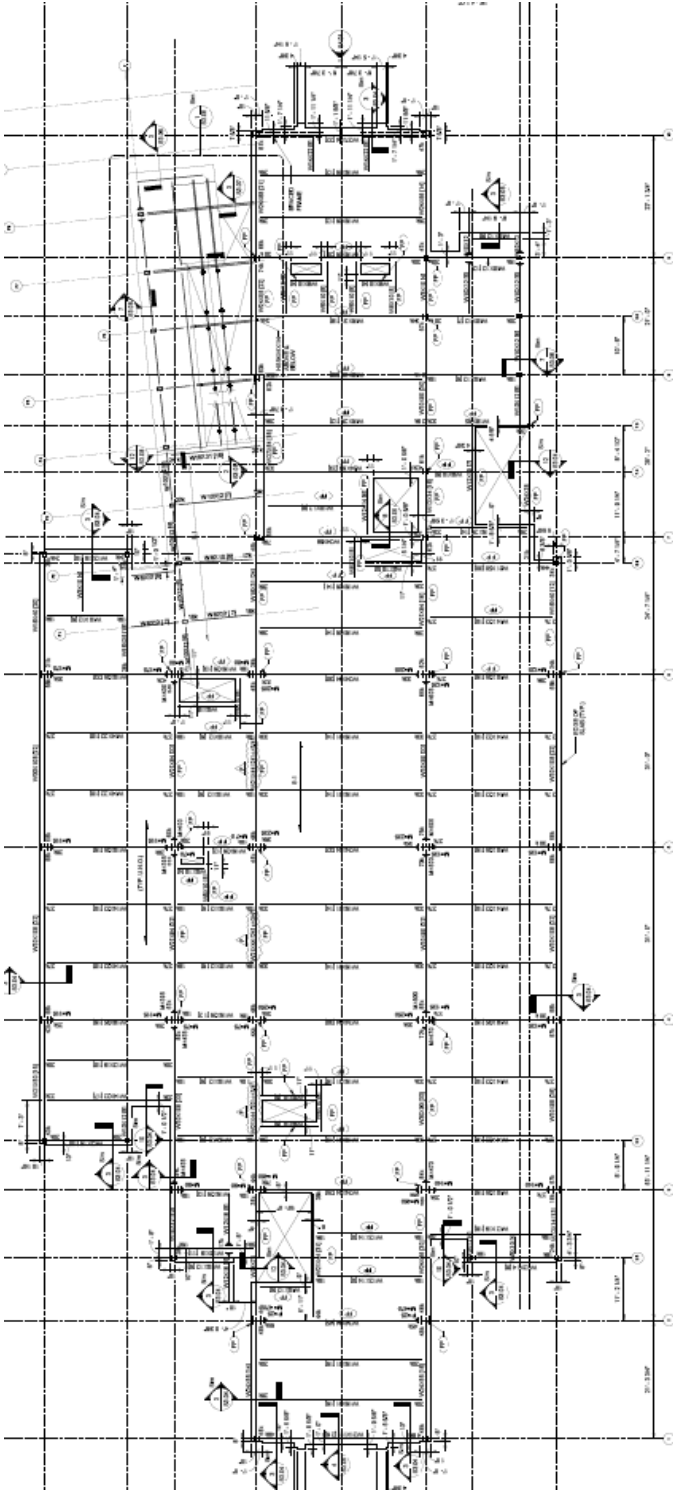

Figure 6: Typical Floor Framing Plan

# Tech 3 Report

Daniel Bodde

Advisor: Heather Sustersic

## Lateral System

The BBH Building uses two types of lateral force resisting systems, moment frames and an eccentric braced frame. These systems are used to resist lateral forces placed on the structure due to wind and seismic loads.

The moment frames are in both the N-S and E-W direction. Frames resisting N-S loads go from column line 2 to column line 6. Frames resisting E-W loads are only located along column lines B and D. This type of system is use on every level above grade. These moment frames are accomplished by designing a rigid connection between the beams and columns. A rigid connection is created by welding the top and bottom flange of the beam to the column as shown in Figure 7. Location of the moment connections are shown below in Figure 8. Due to the irregular layout of the east portion of the building, placement of a moment frame there was not a feasible solution to resist lateral loads. The solution was to place an eccentric braced frame along the exterior of the east elevation. An elevation of the eccentric braced frame is show in Figure 9 on the next page. With the addition of the braced frame the BBH Building is classified as having a dual lateral system.

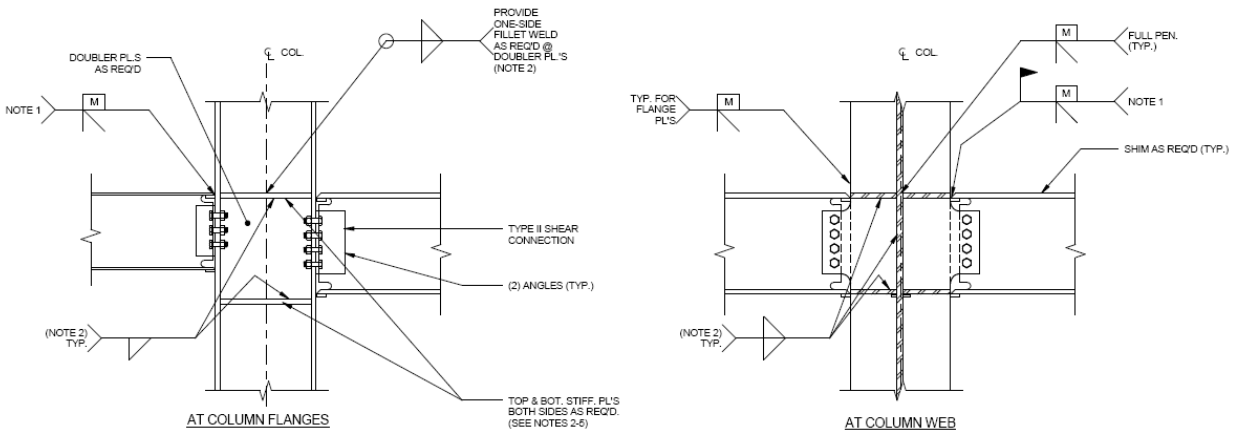

Figure 7: Typical Beam to Column Moment Connection



# Tech 3 Report

Daniel Bodde

Advisor: Heather Sustersic

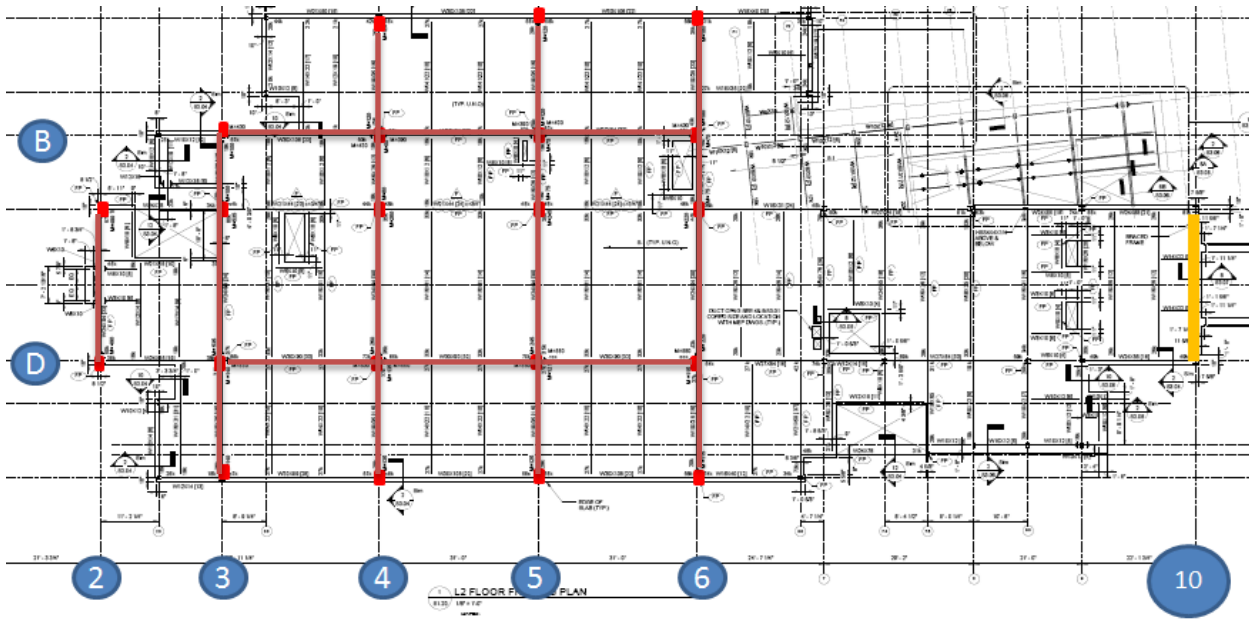

Figure 8: Location of Moment Frames (Red) and Braced Frame (Orange)

There is only a single eccentric braced frame in the BBH Building. It is located on the east side of the building along column line 10 (See Figure 8 above). Figure 9 shows the chevron bracing system used. Lateral movement in the frame is resisted through tension and compression in the HSS braces.

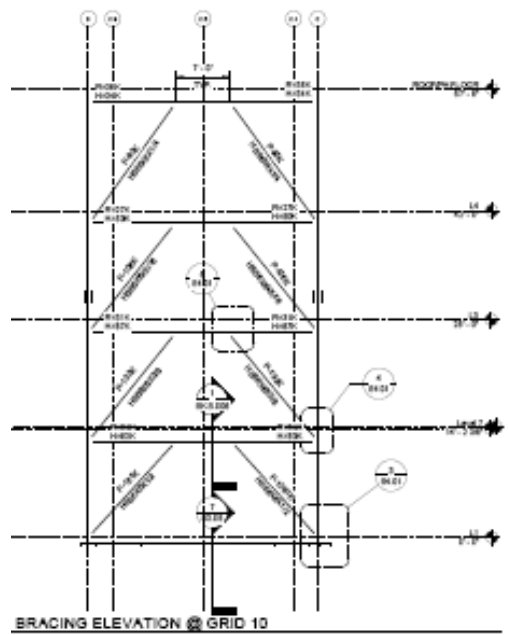

Figure 9: Eccentric Braced Frame

# Tech 3 Report

Daniel Bodde

Advisor: Heather Sustersic

---

## Design Codes

The BBH Building was designed using the following codes:

- IBC 2006 (as amended by Pennsylvania UCC administration)
- ASCE 7-05
- ACI 318-05
- ACI530/ASCE 5
- AISC, 13<sup>th</sup> Edition

For this thesis the following codes were used in the analysis for the BBH Building:

- AISC, 14<sup>th</sup> Edition
- ASCE 7-05

## Material Properties

Steel	
Wide flange shapes	A992 or A572, $f_y=50\text{ksi}$
Square and round steel tubing	ASTM A500, Grade B
Miscellaneous shapes, channels and angles	A36, or A572, $f_y=50\text{ksi}$
Round pipes	A53, Grade B, $f_y=35\text{ksi}$
Plates	A36, $f_y=36\text{ksi}$
Anchor Rods	ASTM F1554, Grade 55
Bolted connections for beams and girders	A325 or F1852, 3/4" diameter
Welded headed shear studs	A108 3/4" diameter
Stainless steel hanger rods	ASTM A564 Type 17-PH $f_y=50\text{ksi}$

Concrete	
Type	28 day compressive strength
Foundations	4000 psi
Slabs and beams	4000 psi

# Tech 3 Report

Daniel Bodde

Advisor: Heather Sustersic

---

Reinforcement	
Deformed Bars	ASTM A615, Grade 60
Welded Reinforcing Steel	ASTMA706 Grade 60
Welded Wire Fabric	ASTM A185

## Design Loads

The following design loads given by the designer.

### Dead

Dead Loads * (psf)	
Slate roof assembly	32
Green roof assembly	60
Floor, typical	60
Floor, stone tile	85
Plaza (above auditorium)	212
* self-weight of steel framing members not included	

## Tech 3 Report

Daniel Bodde

Advisor: Heather Sustersic

---

### Live

Live Load	Uniform (psf)	Concentrated (lbs)
Offices/Classrooms	80(1)	-
Lobbies/Assembly	100	2000(5)
Corridors, Stair	100	2000(5)
Mechanical Rooms	150(3)	-
Roof	30(2)	-
Plaza	125(4)	-
Assembly (fixed seats)	60	-
Heavy storage	250	2000(5)
1. Includes 20 psf partition load		
2. Or Snow Load whichever is greater		
3. Used in absence of actual weight of mechanical equipment		
4. Used for roof over lecture Hall		
5. Concentrated load shall be uniformly distributed over a 2.5 sq ft area and shall be located so as to produce maximum load effects in the structural members		

### Snow

The drift load was calculated for the penthouse green roof as that is where the most drift would accumulate.

Snow Load Type	Uniform (psf)
Flat Roof Load	21
Sloped Roof Load	24
Drift Load	89.5

## Tech 3 Report

Daniel Bodde

Advisor: Heather Sustersic

---

### Problem Statement

A situation has arisen where the use of structural steel has become an unfeasible option for the structural system of the BBH Building. It is to be assumed that this change was made after the structural system had already been designed in steel. The owner has requested that the design professionals keep the original layout and look of the building as close as possible to the original design.

This change will obviously cause structural impacts that will require the floor system, lateral system, foundation system to be redesigned with a different material. In order to cause the least amount of change to the original layout of the building special attention will need to be taken in certain areas. The new floor system will need to be sensitive to the floor to ceiling height impact as an increased floor system depth is undesirable. The new lateral system must be designed to not affect the layout of the floors and also not disturb the open public areas of the BBH building.

These changes in structure will result in modifications needed to be made to the schedule for construction. Using a different material will require the coordination during construction to be adjusted to minimize the schedule impact. Changes in the method of construction of certain aspects of the building might need to be adjusted in order to save time and money during construction.

### Proposed Solution

The alternative structural material selected for the BBH Building will be reinforced concrete. The floor system will consist of flat slabs with drop panels and/or one way slabs with interior beams. These systems were proven to have a total system depth less than that of the original steel design. This will allow for a greater amount of area above the ceiling for MEP equipment to run which can reduce the number of conflicts that are bound to arise during construction. Using reinforced concrete will increase the weight of the building which will cause an increase in the foundation.

In order to resist lateral loads a concrete moment frame will be designed. This type of system will cause the least amount of impact on the existing layout of the building considering the original designed was predominantly a steel moment frame. A square foot cost analysis will be done to compare the existing steel structure to the propose reinforced concrete structure. The effects on the schedule will be studied later in one of the breadth topics.

## Tech 3 Report

Daniel Bodde

Advisor: Heather Sustersic

---

### Breadth Topics

#### Façade Study

The existing façade, consisting largely of brick and limestone, was specified by the architect to be handmade. This method of construction is very expensive due to the amount of physical labor that is involved in laying each piece one by one. An alternate façade system will be used to alleviate the assumed cost and time impact that the concrete redesign will have on the building.

A precast masonry system will replace the existing façade design. This change will affect the detailing and constructability of the façade. Therefore a study will be done to understand how the new façade will change the way the building will need to be insulated, waterproofed, and connected to the structure. A square foot cost analysis will be done to compare the existing façade system to the new precast façade system. The effects on the schedule will be studied in the next breadth topic.

#### Construction Management

The purpose of this breadth is to create a schedule based on the changes that were made in the above depth and breadth. Both of these changes will affect the critical path and will need to be sequenced in a way to better control the flow of the project. Tools such as RS Means and Microsoft Project will be helpful in assembling the schedule. In order to develop a realistic schedule, critical site information may need to be requested from the construction manager. The proposed adjusted schedule will be compared to the existing schedule. It is there we will be able to understand how each of the changes affected the overall project.

# Tech 3 Report

Daniel Bodde

Advisor: Heather Sustersic

---

## Tasks and Tools

### Concrete Redesign (Depth)

1. Redesign Gravity Structure
  - A. Design floor system for typical floor using ACI
  - B. Adjust column layout if needed
  - C. Size columns to carry gravity loads
  - D. Increase foundations if need be
  - E. Model gravity system in SPslab and SPcolumn
  - F. Check for adequacy
  - G. Adjust design
2. Redesign Lateral Structure
  - A. Adjust wind and seismic loads using AISC 7-10
  - B. Determine location of moment frames and design
  - C. Model lateral system in ETABS
  - D. Adjust design
3. Cost impact
  - A. Determine cost of existing steel structure (per square foot)
  - B. Determine cost of redesign (per square foot)
  - C. Compare

### Façade Study (Breadth 1)

1. Precast System
  - A. Determine size and weight
  - B. Determine connection to structure
  - C. Determine waterproofing system
  - D. Determine insulation system
  - E. Develop section detail in AutoCAD
2. Cost Impact
  - A. Determine cost of existing façade structure
  - B. Determine cost of façade redesign
  - C. Compare

### Construction Management (Breadth 2)

1. Research
  - A. Interview CM about existing site conditions affecting schedule
  - B. Request CM for site logistics and existing schedule
  - C. Determine task durations using RSmeans

# Tech 3 Report

Daniel Bodde

Advisor: Heather Sustersic

---

2. Schedule
  - A. Determine sequencing for structure
  - B. Input schedule data into Microsoft Project
  - C. Compare schedules



# Tech 3 Report

Daniel Bodde

Advisor: Heather Sustersic

## Schedule

		Thesis Semester Schedule															
		Daniel Bodde															
		Advisor: Heather Sustersic															
		1/7/2013	1/14/2013	1/21/2013	1/28/2013	2/4/2013	2/11/2013	2/18/2013	2/25/2013	3/4/2013	3/11/2013	3/18/2013	3/25/2013	4/1/2013	4/8/2013	4/15/2013	4/22/2013
1/28/2013 Milestone 1	Research Alternate Column Layout																
	Design typical floor gravity structure																
	Design of Lateral System																
	ETABS Model																
2/11/2013 Milestone 2	Adjust Foundations to Support Additional Load																
	Adjust and Finalize Building Structure																
	Determine WP & Insulating Systems																
	AutoCAD																
3/1/2013 Milestone 3	Research Site Logistics																
	Construction Sequencing																
	Rsmeans: Durations																
	Input Schedule in Software																
3/25/2013 Milestone 4	Finalize Report & Presentation																
	Jury Presentations																
	Update CPEP & Report																
	Senior Banquet TBA																
Milestones																	
1	Depth Gravity System Complete																
2	Preliminary Lateral System Complete																
3	Depth Design Complete																
4	Breadth Investigation Complete																

## Tech 3 Report

Daniel Bodde

Advisor: Heather Sustersic

---

### Conclusion

The BBH Building will be redesigned using reinforced concrete. This means that the floor and lateral systems will have to be redesigned using this new material. Solutions to this redesign include two-way flat slabs, one-way slabs with interior beams, and concrete moment frames. The foundations will then be checked for adequate strength due to the increased load it will see. Then a façade study will be done by changing the façade to a precast system. This will hopefully alleviate the assumed time and cost impacts due to the concrete redesign. From this a new schedule will be constructed to better understand the impact these changes will have on the project.

Tasks and tools were listed to better understand what steps will need to be taken in order to complete this thesis. These steps were then put in to a schedule to show the duration of how long each step should take to complete.